

KOHLER Diesel KD15



KOHLER Engines



IN ORDER TO MEET EVER INCREASING MARKET DEMANDS, THE KOHLER GROUP HAS BEEN UPDATING ITS RANGE OF AIR-COOLED, SINGLE CYLINDER DIESEL ENGINES. NOW, WE ARE PLEASED TO PRESENT THE NEW KD15 440 ENGINE,

WHICH, WITH ITS ADVANCED TECHNICAL FEATURES, STRENGTHENS AND IMPROVES THE CURRENT 15 LD ENGINE SERIES ELEVATING IT TO THE VERY TOP OF THE CLASS WITHIN ITS POWER RANGE.

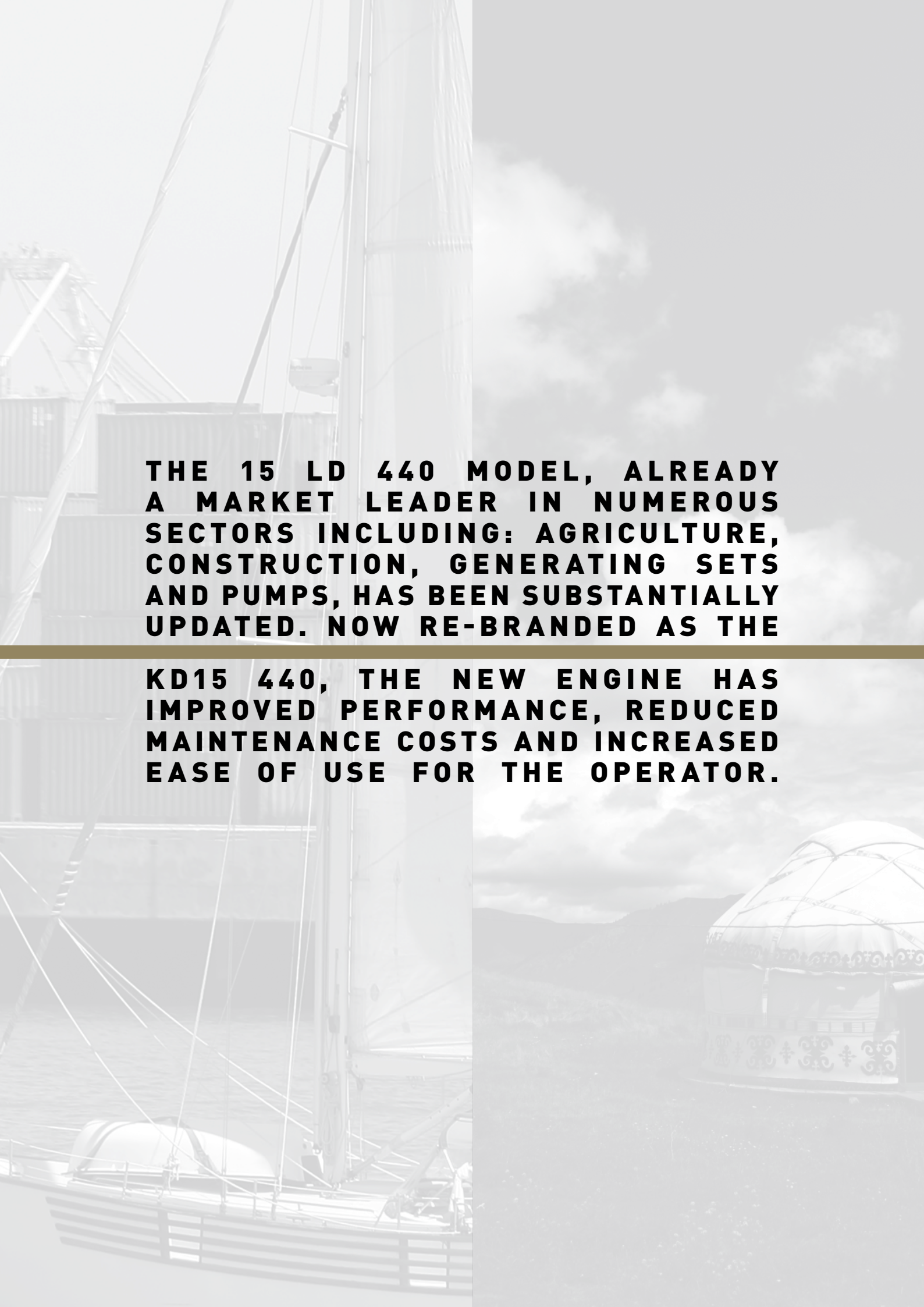

THE 15 LD 440 MODEL, ALREADY A MARKET LEADER IN NUMEROUS SECTORS INCLUDING: AGRICULTURE, CONSTRUCTION, GENERATING SETS AND PUMPS, HAS BEEN SUBSTANTIALLY UPDATED. NOW RE-BRANDING AS THE

KD15 440, THE NEW ENGINE HAS IMPROVED PERFORMANCE, REDUCED MAINTENANCE COSTS AND INCREASED EASE OF USE FOR THE OPERATOR.

AIR CLEANER

The new air filter allows an use also in extremely dusty conditions. This result has been achieved thanks to a high efficiency separator with pre-filter (optional) and an accumulated-dust drain valve in the filter itself. Furthermore, the increased dimensions of the cartridge and the high filtration capacity of the paper element greatly enhances the engine protection, resulting in a considerable reduction in maintenance costs.

TANK AND FUEL FILTER

The new tank, with its modified components, greatly contributes to facilitating all maintenance operations due to some significant improvements, including a new fuel filter which is enhanced with additional safety filter protection. The primary filter (optional) and the safety one, used in tandem, avoid the accidental entry of foreign particles during the fuel refilling process. The primary filter housed inside the tank is easily accessible and can be replaced without the use of any special tools.

DRAIN TAP

The new drain tap makes it possible to remove water and impurities which accumulate in the bottom of the tank, allowing for cleaning without the need to dismantle other components.



INNOVATIONS

AIR CLEANER CLOGGING INDICATOR (OPTIONAL)

The air filter clogging indicator integrated into the engine configuration makes it possible to clearly see when maintenance is required.

LARGER OIL SUMP (OPTIONAL)

The larger oil sump increases the intervals between maintenance to 500 hours as opposed to 250 hours in standard versions.

HEAVY DUTY ROBUSTNESS

BEST AIR CLEANER SERVICE

EASY MAINTENANCE

LONG SERVICE INTERVALS



EXCELLENT FUEL EFFICIENCY

LOW OIL CONSUMPTION

REDUCED NOISE

HIGH RELIABILITY

KD15 440



STANDARD EQUIPMENT

Recoil starting with automatic compression release
Muffler with guard
Accelerator and stop manual control
External safety fuel filter

- NEW!** High capacity dry air cleaner
- Hydraulic tappets
- User maintenance & spare parts booklet
- NEW!** Fuel tank drain tap
- 3 years extended warranty

ACCESSORIES ON DEMAND

- NEW!** Internal fuel pre-filter
- Power take-off flywheel side (engines with electrical starting)
- Power take-off with flanging and special shaft
- Internal dynamic balancer
- NEW!** Cyclonic air intake pre-filter
- Oil bath air cleaner
- Electric start 12 V / 24V
- Keyswitch panel
- Emergency stop through electrovalve
- Accelerator and stop remote control
- Single lever control
- Control lever guard
- Fuel lift pump
- Oil pressure switch
- Oil temperature switch
- Glow plug on intake manifold
- Recoil with denoising cover
- Grass protection for engine cooling.
- NEW!** Air filter clogging indicator, integrated into the engine construction form
- NEW!** Oversize oil sump
- External spin on oil filter



KOHLER[®]

KOHLER

KD15 440

QUICK SPECIFICS

1
CYLINDER

10.9 | **8** @ 3600 rpm
HP | kW

24.5 @ 2200 rpm
Nm



DATA

DIMENSIONS (mm)

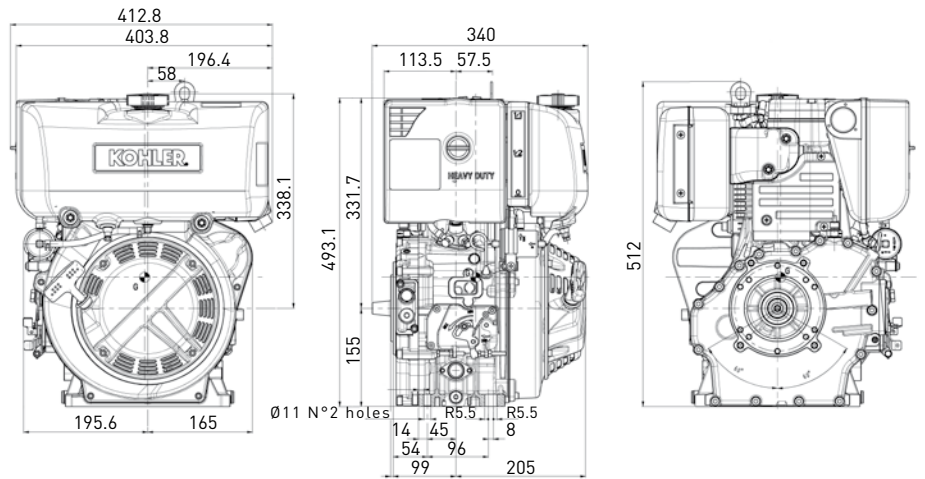

PERFORMANCE CURVE (IFN- ISO 3046 AND ISO 14396)

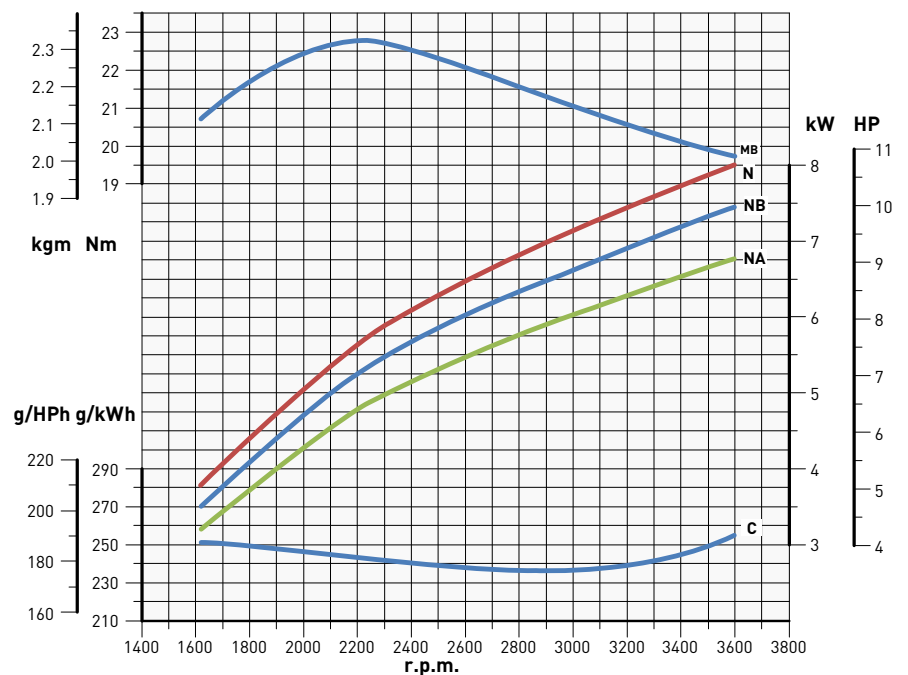

N - Power curve - 80/1269/CE E-ISO 1585

MB - Torque curve - (NB curve)

NB - Power curve - ISO 3046/1 -IFN

C - Specific fuel consumption - (NB curve)

NA - Power curve - ISO 3046/1 - ICXN

Power ratings refer to engines equipped with air filter, standard muffler, after running-in period at ambient conditions of +25°C, relative humidity 30% and 1 bar. Power levels drop by 1% every 100 m altitude and by 2% every 5°C above +25°C.

KD15 440S



QUICK SPECIFICS

1
CYLINDER

10 | **7.3** @ 3600 rpm
HP | kW

22.5 @ 2100 rpm
Nm

DATA

DIMENSIONS (mm)

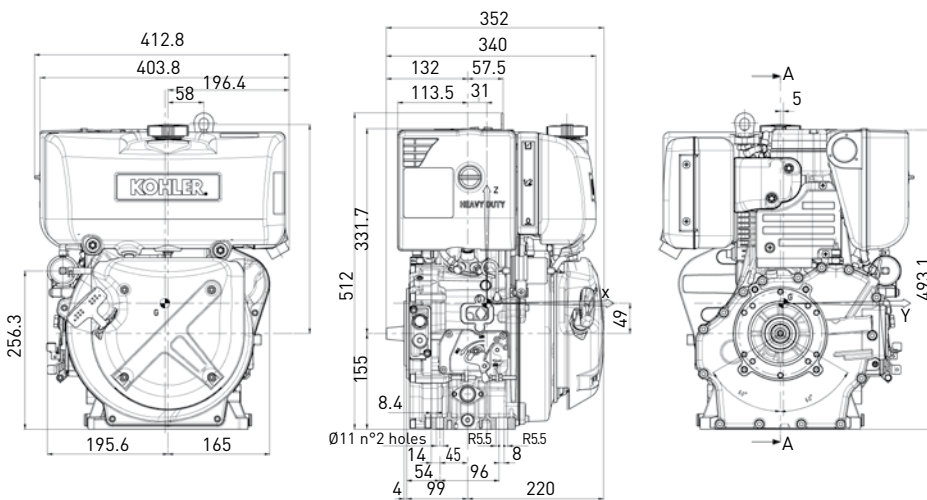

Sound pressure level up to 2 Db less than the standard version

PERFORMANCE CURVE (IFN- ISO 3046 AND ISO 14396)

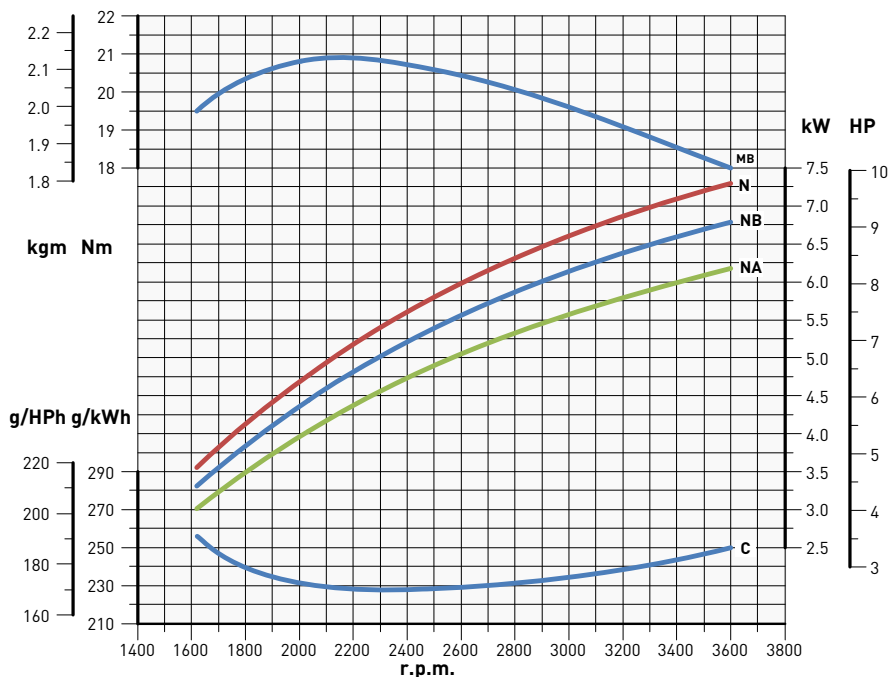

N - Power curve - 80/1269/CE E-ISO 1585

MB - Torque curve - (NB curve)

NB - Power curve - ISO 3046/1 -IFN

C - Specific fuel consumption - (NB curve)

NA - Power curve - ISO 3046/1 - ICSN

Power ratings refer to engines equipped with air filter, standard muffler, after running-in period at ambient conditions of +25°C, relative humidity 30% and 1 bar. Power levels drop by 1% every 100 m altitude and by 2% every 5°C above +25°C.

AVAILABLE FLANGES*

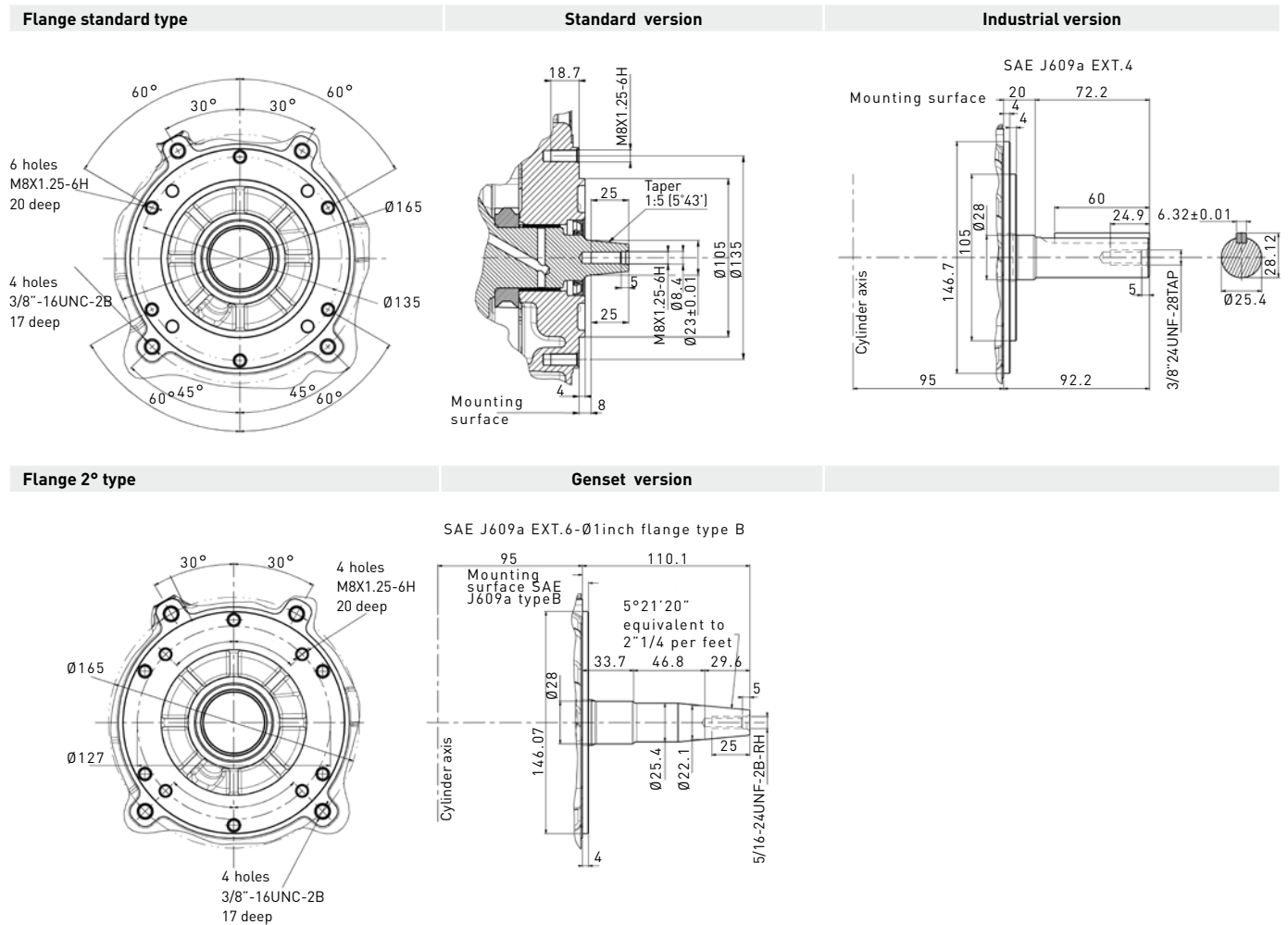

*Other flanges available on request

APPLICATIONS SPECS

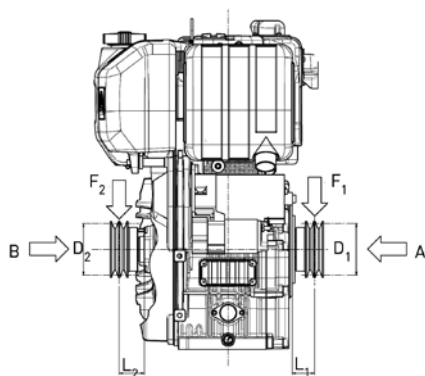

Minimum pulley diameters for belt drive

$$D_2 \text{ (mm)} \geq 620 [66 + L_2 \text{ (mm)}] \frac{N \text{ (kW)}}{n \text{ (rpm)}}$$

$$D_1 \text{ (mm)} \geq 650 [53 + L_1 \text{ (mm)}] \frac{N \text{ (kW)}}{n \text{ (rpm)}}$$

Max intermittent axial load in both directions
A - B = 2000 N Max

Max radial force on pulley for belt drive

$$F_1 \text{ (N)} \leq \frac{89000}{53 + L_1 \text{ (mm)}}$$

$$F_2 \text{ (N)} \leq \frac{92000}{66 + L_2 \text{ (mm)}}$$

TECHNICAL SPECIFICATIONS

Model		KD15 440		KD15 440S
Engine specs	4 stroke air cooled diesel engine	•		•
	Conical power take-off on crankshaft	•		•
	Anticlockwise rotation	•		•
	Forced lubrication with oil pump	•		•
	Centrifugal mass governor	•		•
	Built-in full flow oil filter	•		•
	Oil breathing blow-by with safety device	•		•
	Automatic extra fuel starting device	•		•
	Self bleeding fuel system	•		•
	Torque adjuster	•		•
	Automatic compression release	•		•
	Die-cast aluminum crankcase with integral cast iron cylinder liner	•		•
	Aluminum cylinder head	•		•
	Built-in rigid feet	•		•
	Hydraulic tappets	•		•
Dry air cleaner with cyclonic pre-filter	•		•	
Primary and secondary fuel filter	•		•	
Technical features	Cylinder	1		1
	Bore (mm)	86		86
	Stroke (mm)	76		76
	Engine displ (cm ³)	441		441
	Injection system	DI		DI
	Compression ratio	20.3:1		20.5:1
Performance	Emission compliance	ECE R 24	EPA TIER 4 Final	-
	Rating (kW/HP) N (80/1269/CEE)ISO 1585 NB ISO 3046 IFN NA ISO 3046 ICXN	8.0/10.9 7.4/10.1 6.7/9.1	6.8/9.2 6.1/8.2	7.3/10.0 6.8/9.2 6.2/8.4
	Max torque (Nm@rpm)	24.5@2200	18.0@3600	22.5@2100
	Min idling speed	1050 ÷ 1150		1150
Fuel compatibility	EN 590	•		•
	No 1 Diesel (US) - ASTM D 975-09 B - Grade 1-D S 15	•		•
	No 1 Diesel (US) - ASTM D 975-09 B - Grade 1-D S 500	•		•
	No 2 Diesel (US) - ASTM D 975-09 B - Grade 2-D S 15	•		•
	No 2 Diesel (US) - ASTM D 975-09 B - Grade 2-D S 500	•		•
	ARCTIC EN 590/ASTM D 975-09 B	•		•
	High Sulfur Fuel < 5000 ppm (< 0.5%)	•		•
	High Sulfur Fuel > 5000 ppm (> 0.5%)	•		•
	Military NATO Fuels F34 - F35 - F44 - F63 - F64 - F65 *	•		•
	Military US Fuels JP5 - JP8 (AVTUR) *	•		•
Civil Jet Fuels Jet A/ A1*	•		•	
Service features	Fuel tank capacity (l)	5		5
	Oil sump capacity (l)	1.5 / 4.6***		1.5 / 4.6***
	Oil consumption (kg/h)	0.0048		0.0048
	Oil consumption (% fuel)	<0.2		<0.2
	Min allowable oil pressure (bar)	0.6		0.6
	Oil change interval std/synthetic (hr)	250**/ 500***		250**/ 500***
	Oil filter change interval std/synthetic (hr)	500		500
	Dry air cleaner change interval (hr)	500		500
	Valve adjustment	not required		not required
Physical characteristics	H × L × W (fan excluded) (mm)	493.1 × 412.8 × 340		493.1 × 412.8 × 352
	Dry weight (kg)	45		45
	Daily service points - positions	1 side service		1 side service
	Ambient operating temps (°C)	-10 to +50		-10 to +50
	Gradeability-all round (continuous) (deg)	25		25
	Gradeability-all round (intermittent-1min) (deg)	35		35
	Cap. of air required for correct combustion @3600 (l/min)	640		640
Cap. of air required for correct cooling @3600 (l/min)	5500		5500	
Lubrication	Oil type	SAE 5W 40 API SERVICE CF		SAE 5W 40 API SERVICE CF

* With restrictions ** According to operating conditions ***With optional oversize oil sump

KOHLER® Engines

Kohler Engines is a brand distributed by Lombardini s.r.l., part of Kohler Group.

Lombardini has manufacturing facilities in Italy, Slovakia and India and sales subsidiaries in France, Germany, UK, Spain and Singapore.

Kohler/Lombardini reserve the right to make modifications without prior notice.

For the latest version please visit our website:

www.lombardini.it

EUROPE

Lombardini Srl
Via Cav. del lavoro
A. Lombardini n° 2
42124 Reggio Emilia, ITALY
T. +39-(0)522-389-1
F. +39-(0)522-389-503

DEUTSCHLAND

Lombardini Motoren GmbH
Silostr. 41,
65929 Frankfurt am Main
DEUTSCHLAND
T. +49-(0)69-9508160
F. +49-(0)69-95081630

UK

Lombardini U.K. Ltd
1, Rochester Barn - Eynsham Road
OX2 9NH
Oxford, UK
T. +44-(0)1865-863858
F. +44-(0)1865-861754

ESPAÑA

Lombardini ESPAÑA, S.L.
P.I. Cova Solera 1-9
08191 - Rubí (Barcelona)
ESPAÑA
T. +34-(0)9358-62111
F. +34-(0)9369-71613

FRANCE

Lombardini France S.a.s.
47 Allée de Riottier,
69400 Limas, FRANCE
T. +33-(0)474-626500
F. +33-(0)474-623945

ROAPAC

Lombardini Singapore
26 Keong Saik Road (3rd floor)
Asia Pacific Represent. Offices
089154- Singapore
T. +65-(0)622-50556
F. +65-(0)622-50551